



Width 10.0 x 10 .0 meters

Metric Sizes

Living area: 82.0 m2

Deck area : 18.0 m2

Total Area: 100.0 m2 includes deck areas

CONCEPT PLANS



Australian Design Services
A Design World Of Difference

www.australianfloorplans.com

Australian Home Design: 100 KR

3 Bed + 2 Bath + 0 Car



Width 10.0 x 10 .0 meters



Metric Sizes

Living area: 82.0 m2
Deck area : 18.0 m2

Total Area: 100.0 m2 includes deck areas



Australian Design Services
A Design World Of Difference

www.australianfloorplans.com

CONCEPT PLANS

NOTES

UNLESS OTHERWISE NOTED,
ALL DOORS TO BE 820

UNLESS OTHERWISE NOTED, WALL THICKNESS
IS AS FOLLOWS:- EXTERNAL WALLS 90
INTERNAL WALLS 90

General notes:

- concrete construction to comply with AS2870 AND AS3600 BCA
- timber construction to comply with AS1684 -2006.
- concrete roofing to comply with AS1757 /AS2050
- wet areas to comply with the provisions of Part 3.8.1 of the bca.
- weepholes in masonry walls at 900 ctrs.
- glass installation to comply with AS1288 and AS2047.
- s denotes smoke detector; smoke alarms to comply with the provisions of Part 3.7.2 of the BCA.
- manhole position approx. only, determine on site.
- provide alcor barrier between lead flashing and zincalume valley gutter as required.
- keep hws 100 clear of walls.
- protection of masonry wall ties to comply with the provisions of Part 3.3.3.2 of the BCA.
- protection of lintels in masonry to comply with the provisions of Part 3.3.3.4 of the BCA.
- mechanical ventilation to internal wc to be vented to external air via ducting in accordance with the provisions of part 3.8.5.0 of the BCA 1996.

FLOOR AREAS:		DATE:
Floor	82.00 m ²	SCALE 1 : 100
Deck	18.00 m ²	WIND SPEED: N3
		DRAWN:
		SHEET:
Total	100.00 m²	

CLIENT :

SITE:

DO NOT SCALE OFF.
Written dimensions take precedence

AMENDMENTS

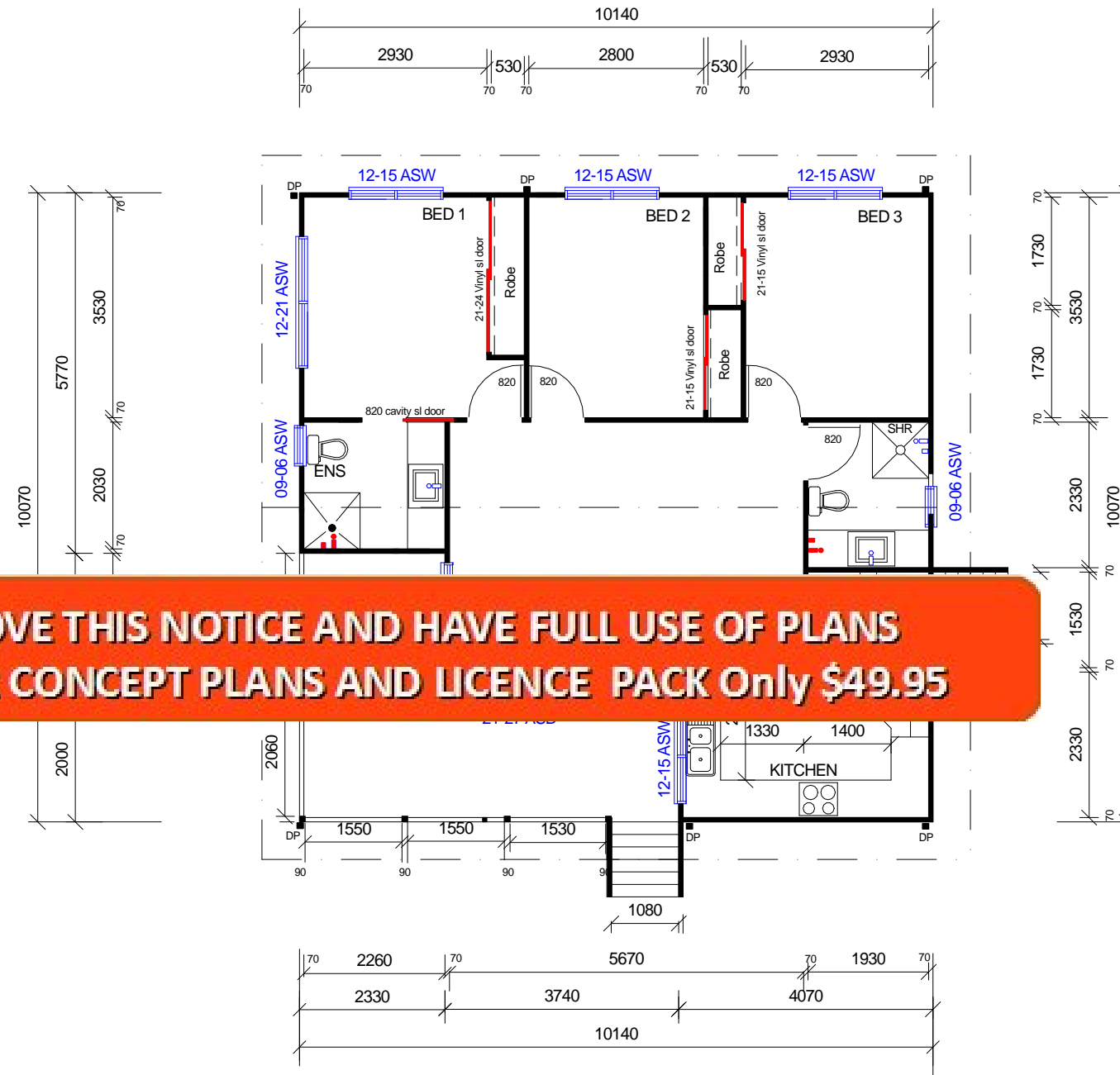

**TO REMOVE THIS NOTICE AND HAVE FULL USE OF PLANS
BUY OUR CONCEPT PLANS AND LICENCE PACK Only \$49.95**



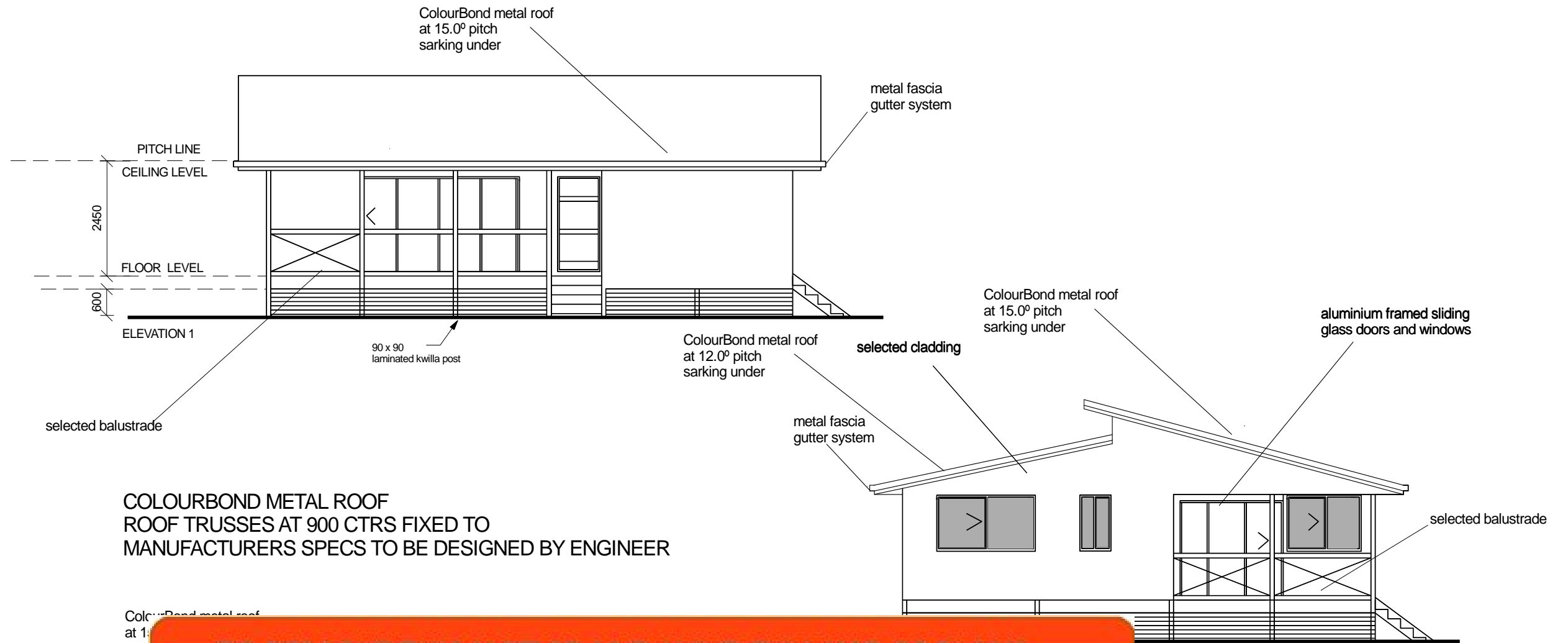

COLOURBOND METAL ROOF
 ROOF TRUSSES AT 900 CTRS FIXED TO
 MANUFACTURERS SPECS TO BE DESIGNED BY ENGINEER

ColourBond metal roof
 at 12.0° pitch
 sarking under

**TO REMOVE THIS NOTICE AND HAVE FULL USE OF PLANS
 BUY OUR CONCEPT PLANS AND LICENCE PACK Only \$49.95**

ColourBond metal roof
 at 12.0° pitch
 sarking under

FLOOR AREAS:		DATE:
Floor	82.00 m ²	SCALE 1 : 100
Deck	18.00 m ²	WIND SPEED: N3
		DRAWN:
		SHEET:
Total	100.00 m²	

CLIENT :

SITE:

DO NOT SCALE OFF.
 Written dimensions take precedence

AMENDMENTS

10mm SUPERCEIL TO CEILINGS
 10mm PLASTERBOARD TO WALLS

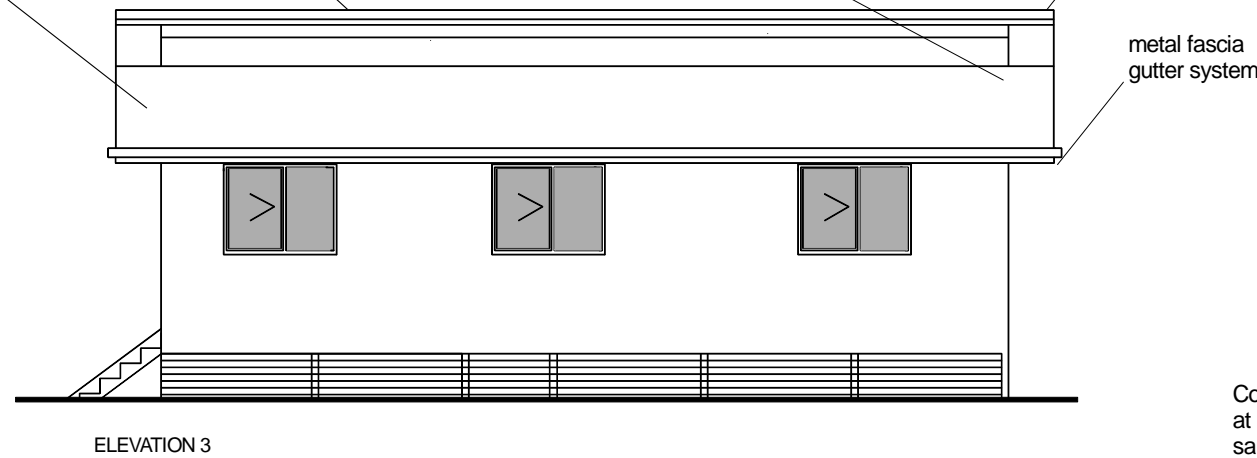

SLAB AND FOOTINGS TO ENGINEER'S DETAIL.
 POISONS TO A.S. 3660.1-2000 STANDARDS.

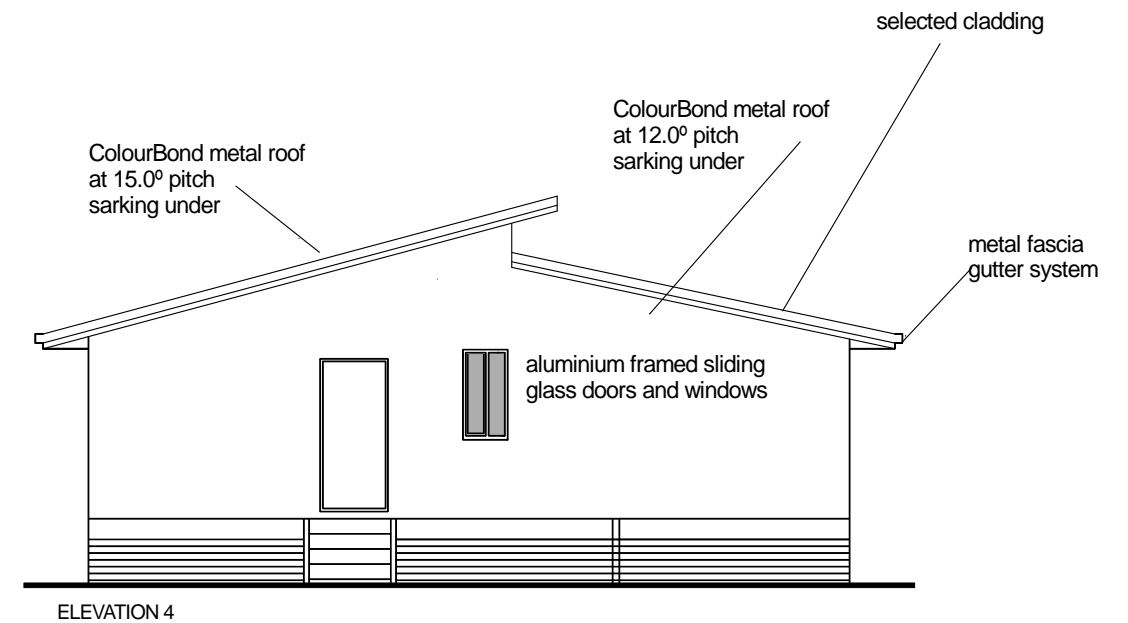

NOTE: IN ADDITION TO TIE DOWN & BRACING REQUIREMENTS, THE BOTTOM PLATE OF ALL WALLS (LOAD & NON-LOAD BEARING) ARE TO BE FIXED TO THE SLAB AS FOLLOWS: HAMMERED, FIRED, SCREWED OR EXPANSION MASONRY FASTENERS AT 1200mm CENTRES ALONG THE PLATE.

construction details

reference codes:

instruction to be in accordance with the

general specifications

preliminaries:

all construction methods, materials, & workmanship must comply with the building act and subsequent amendments and all australian standards referred to therein. it is the builders responsibility to verify the contents of this document before construction is commenced. written measurements are to the face of the timber framing or the brickwork and are to take preference over scaled measurements. all levels are to be verified on site.

concretor:

all concrete shall comply with a.s. 3600. footings and slabs shall comply with a.s. 2870-1995. where local authorities require soil tests and engineered footing and slab details, these engineered details take preference over drawn details. the method of termite control shall comply with a.s.3660.1

carpenter:

all timber sizes are the minimum required under AS.1684.2 walls are 2400 single/upper & 2700 lower storey unless otherwise noted. wc doors are to be fitted with lift off hinges timber sizes to be as per table 1. tie down to be as per table 2. and as specified on plan. roof trusses to be as per engineered design by authorised manufacturers. fixing to be as per table 2. trusses to be braced strictly in accordance with the manufacturers recommendations. lintel sizes as per table 3.

other trades:

unless otherwise specified: the walls to be sheeted with 10mm thick gypsum plasterboard, 6mm thick villaboard to wet areas. ceilings to be 10mm thick gypsum plasterboard where roof trusses/ceiling joists are at 900mm centres roof sheeting to be fixed in accordance with the manufacturers specifications brickwork shall be straight plumb and level (within tolerances as allowed in the australian standards code for brickwork) and have veneer ties at maximum 600mm centers horizontally and vertically. smoke alarms to comply with b.c.a. class 1 & 10 part 3.7.2 and with a.s. 3786.

table 2. (tie down) 1storey sheet roof N3

type A	battens to rafters/trusses at 900crs max	edges - 2.3kN - 1/75 long No. 14 type17 screw(4.5kN) general - 1.2kN - 1/75 long No. 14 type17 screw(4.5kN)
type B	rafter/truss to plate (ULW - 7500)	required - 8.9kN 900crs 1/30x0.8 GI looped strap with 4/2.8mm ϕ nails each end (13.0kN)
type C	top plate to stud (ULW - 7500)	required - 6.8kN 900crs 1/30x0.8 GI looped strap with 6/2.8mm ϕ nails each end (8.4kN)
type D	plates to floor	Nominal fixing only. (as per AS.1684.2, Table 9.2) 1/75mm masonry nail (hand-driven at slab edge.) screw or bolt at max 1200crs

table 3. (standard lintel schedule)
studs 600crs max 2.7 ceiling height

1500	3	2/140x35 pine mgp12	3	190x35 pine mgp12
1800	3	2/190x35 pine mgp12	3	190x35 pine mgp12
2100	3	2/190x35 pine mgp12	3	2/190x35 pine mgp12
2400	4	2/190x35 pine mgp15	4	2/190x35 pine mgp12
2700	4	2/240x35 kd mgp12	4	2/220x35 kd mgp12
3000	4	2/240x35 kd mgp15	4	2/240x35 kd mgp12
opening	jamb studs	ULW 4500		
900	2	90x35 pine mgp12		
1200	2	140x35 pine mgp12		
1500	2	140x35 pine mgp12		
1800	3	190x35 pine mgp12		
2100	3	190x35 pine mgp12		
2400	3	2/190x35 pine mgp12		
2700	3	2/190x35 pine mgp15		
3000	3	2/220x35 kd mgp15		

NOTE: FOR LINTELS SUPPORTING GIRDER TRUSSES REFER TO FLOOR PLAN OR FRAME MANUFACTURER'S DETAILS

steel lintels supporting upper brickwork only

UP TO 1000mm:	85x8 FLAT BAR. 90mm END SUPPORT
1001mm TO 2100mm:	100x100x6 ANGLE. 100mm END SUPPORT
2101mm TO 3600mm:	150x100x8 ANGLE. 100mm END SUPPORT

REFER TYPE A (table 2)

REFER TYPE B (table 2)

0-600
EAVES

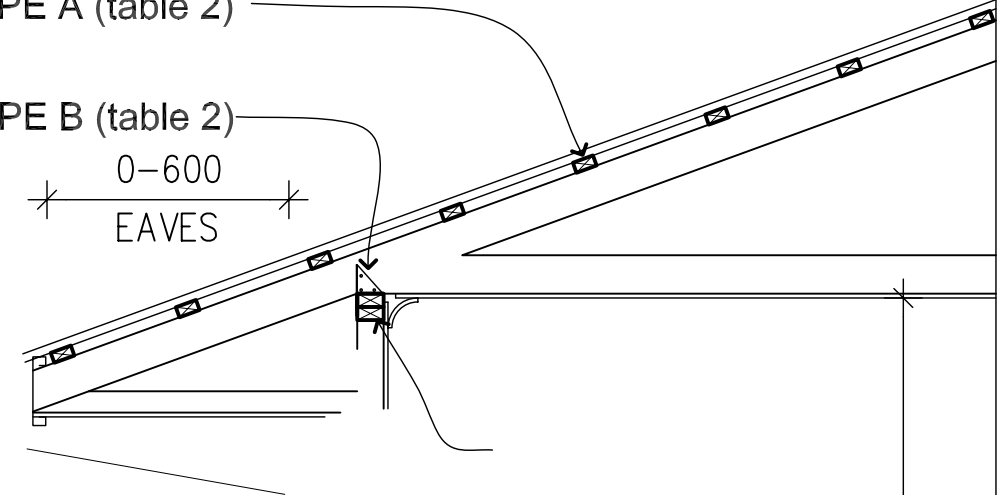

2440-3040

T

FINISHED FLOOR LEVEL

SECTION DETAIL

termite protection: slab edge exposure for slab perimeter. For penetrations & control joints use stainless steel mesh by RE-TIC PEST MANAGEMENT ph: 0409647483



**TO REMOVE THIS NOTICE AND HAVE FULL USE OF PLANS
BUY OUR CONCEPT PLANS AND LICENCE PACK Only \$49.95**

FLOOR AREAS:		DATE:
Floor	82.00 m ²	SCALE 1 : 100
Deck	18.00 m ²	WIND SPEED: N3
		DRAWN:
		SHEET:
Total	100.00 m ²	

CLIENT :

SITE:

DO NOT SCALE OFF.
Written dimensions take precedence

AMENDMENTS

ELECTRICAL PLAN

	meter box		fluorescent light - 1200 single		single g.p.o. 1050 above floor level		M microwave g.p.o. 1650 a.f.l. if req'd		hws hot water service
	light switch 1350 above floor level		exhaust fan		dbble g.p.o. 1050 above floor level		H rangehood g.p.o. 1650 a.f.l. if req'd		S smoke detector
	ceiling light - batten holder		ceiling fan		vanity d.g.p.o. 1100 above floor		TV television outlet		CF ceiling fan light
	wall mounted light		single g.p.o. 300 above floor level		G garage d.g.p.o. 1350 above floor		P telephone outlet 300 above floor		15 split air-conditioning g.p.o.
	downlight		dbble g.p.o. 300 above floor level		R refridg. g.p.o. 1650 above floor		P telephone outlet 1650 above floor		E Ethernet data

wind bracing - N3

direction a	panel	no. off	structural plywood 6kN/m method B	tb.1a a/b & n.p g.i. strap 1.5kN/m	rod, conc 2.25kN	sub total and total
	A1	6	5.4			32.4
	A2					
	A3					
	A4					
	A5					
	resistance gained					32.4 kN
	resistance required					29.8 kN
	B1	6	5.4			32.4
	B2					
	B3					
	B4					
	B5					
	resistance gained					32.4 kN
	resistance required					29.8 kN

FLOOR AREAS:		DATE:
Floor	82.00 m ²	SCALE 1 : 100
Deck	18.00 m ²	WIND SPEED: N3
		DRAWN:
		SHEET:
Total	100.00 m ²	

CLIENT :

SITE:

DO NOT SCALE OFF.
Written dimensions take precedence

AMENDMENTS

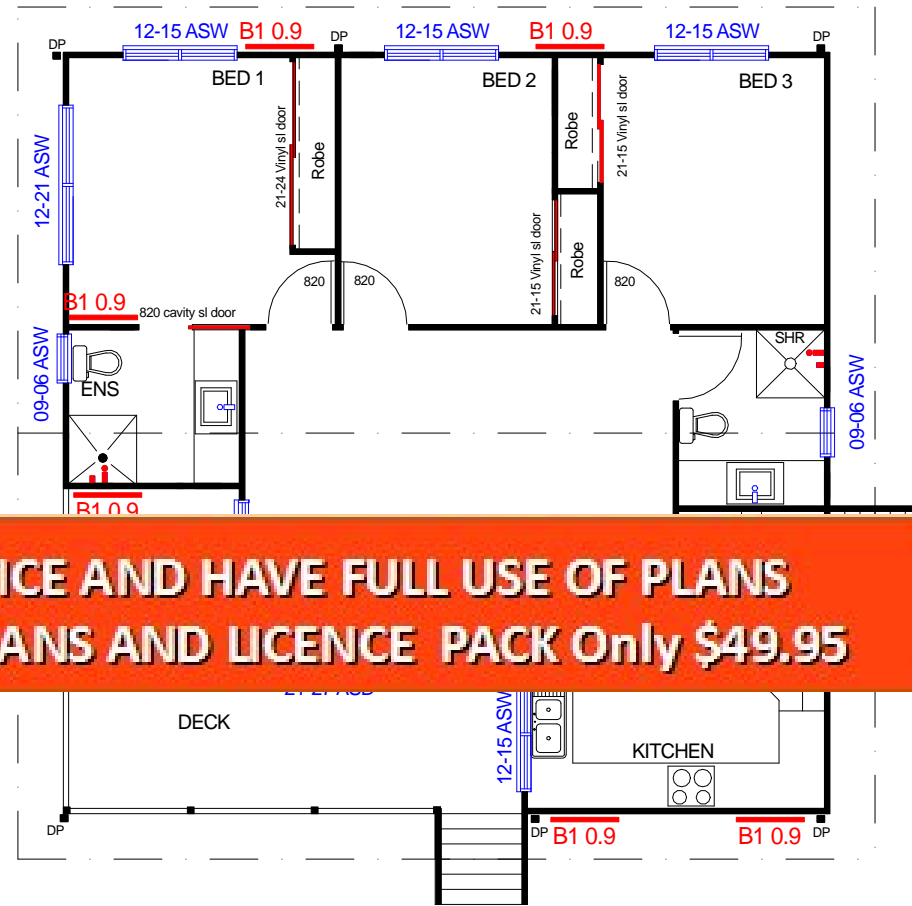

**TO REMOVE THIS NOTICE AND HAVE FULL USE OF PLANS
BUY OUR CONCEPT PLANS AND LICENCE PACK Only \$49.95**

BRACING PLAN

BUY OUR FULL CONCEPT PLANS AND LICENCE PACK Only \$49.95

About Our Concept Home Plans

Our concept house plans were created as preliminary house plans for clients or builders.

Choose a plan and tweak it to your lifestyle or have us complete the plans as is. As an option, you can have your local home designer complete the full construction plans for you or we can offer you a low cost set of working drawings ready for construction.

This free pack will have the copyright watermark removed and you will have the full use of the plans.

Included In Our Concept Plans & Copyright Pack:

- Concept plan
- Concept Elevations
- Copyright to use plan
- PDF so you can print off as many as you want

**TO BUY
CLICK HERE**

INCLUDED IN CONCEPT PLANS AND LICENCE PACK

Australian Home Design: 100 KR 3 Bed + 2 Bath + 0 Car



Width 10.0 x 10.0 meters

Metric Sizes
Living area: 82.0 m²
Deck area: 18.0 m²
Total Area: 100.0 m²

Design Services
World Of Difference
austrianfloorplans.com

Example only

Australian Home Design: 100 KR 3 Bed + 2 Bath + 0 Car



Width 10.0 x 10.0 meters

Metric Sizes
Living area: 82.0 m²
Deck area: 18.0 m²
Total Area: 100.0 m²

Design Services
World Of Difference
austrianfloorplans.com

Example only



Example only

WATERMARK IS REMOVED SO YOU CAN FULLY USE THE PLANS

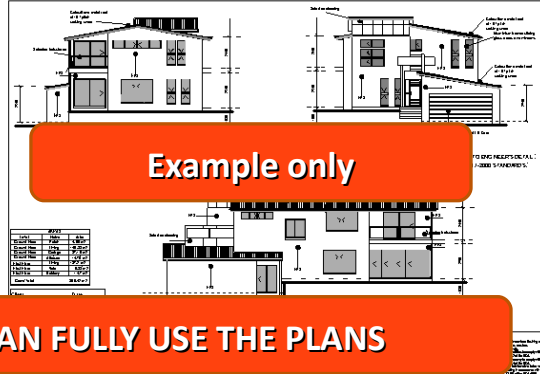

Example only

Australian floor plans

COPYRIGHT LICENSE

The copyright is recorded in our records, yours is recorded in Your Name, with the copy right to build one time at any location, making changes in full or in part. This includes worldwide right to build

LICENSE Australian floor plans hereby grants you the non-exclusive worldwide rights

To build in part or in full. License to use the plan on literature, used as a guide for house planning one time only. License to build the design or part thereof once per licence fee, one time only.

WHEREAS, Australian Floor Plans DOES NOT INCLUDE Documents and T

Example only

Please Note:

All construction plans ordered through the Australian Floor Plans and Brockston Pty Ltd are provided as-is and Australian Floor Plans and Brockston Pty Ltd disclaims all other warranties, express or implied, including merchantability or fitness of purpose. Construction plans may not be returned for credit and/or refund under any circumstances. Australian Floor Plans and Brockston Pty Ltd is not liable for incidental, special, consequential, or indirect damages of any kind, including, but not limited to, loss of anticipated profits, business opportunity, or other economic loss arising out of the use of services or any construction plans received from Australian Floor Plans and Brockston Pty Ltd even if the Australian Floor Plans and Brockston Pty Ltd is advised of the possibility of such damage.

It is the customer's responsibility to ensure the accuracy, compliance with applicable statute or regulation, and fitness of purpose of any plans or construction information received from Australian Floor Plans and Brockston Pty Ltd prior to use thereof. In the event any liability is imposed on Australian Floor Plans and Brockton Pty Ltd, Australian Floor Plans and Brockston Pty Ltd liability to you or any third party shall not exceed the price paid for Australian Floor Plans and Brockston Pty Ltd product.

All council and state requirements for permits and drafting license are the responsible of the buyer and not the responsibility of Australian Floor Plans and Brockston Pty Ltd.
Conditions:
We are engaged as an employee and you are assumed to be acting as the builder or building Contractor Quote excludes costs for; Council Application, Form 15 & 16 Engineering and Site Contours
Any Payment made is taken as accepting the conditions and that you agree to defend, indemnify and hold harmless Australian floor plans, Brockston Pty Ltd
And its directors and staff for any third-party claims which may arise from the use of the plans or copyright infringements. All payments are non-refundable.

Kind Regards

Peter Martin
Peter Martin.

ARE YOU A BUILDING CONTRACTOR? BUY OUR HOME BUILDERS PACK

Home Builders Pack:

Designed for building contractors. Ideal for websites, blogs, printing, advertising. They come with an **Editable Doc File** so you can place your logo, contact details etc.

Builders Set of Plans Includes

- Preliminary House Plan Set (Digital)
- Editable Doc File
- 3D Front facade JPEG
- 2D Floor plan JPEG
- Copyright to use the plans

Building Contractors Plans and Copyright Licence Pack

- Preliminary House Plan Set (Digital)
- Brochure Plans in PDF format
- Editable Doc File
- 3D Front facade JPEG
- 2D Floor plan JPEG
- Copyright to use the plans

[More Details Here](#)



Example brochure

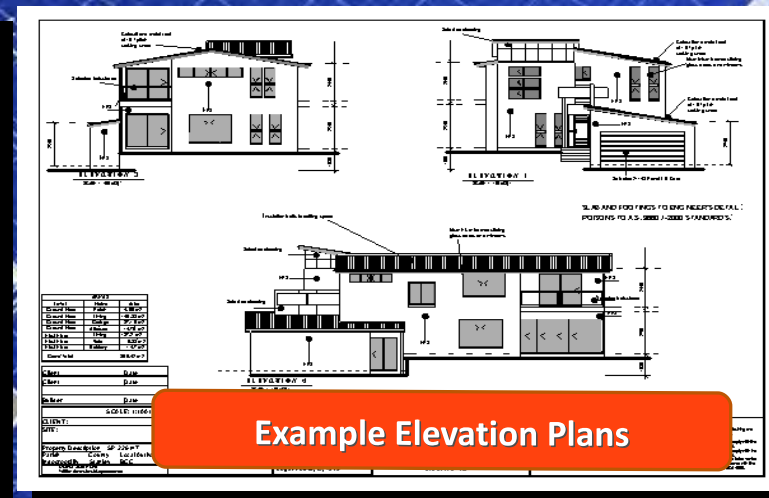
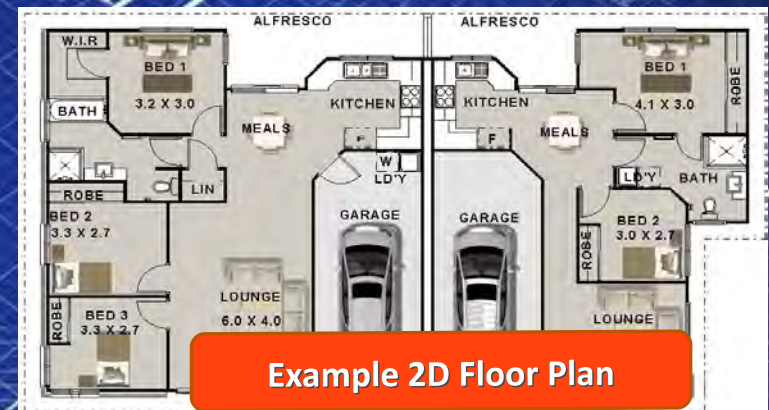

Do you want modifications to this design – OR a custom design? Get our Free Quote

Affordable Low Cost Custom Design Set

A Custom Design Set is a full set of construction plans, we make custom changes as per your requirements. When you request a change to a plan, example room sizes, window changes, layout changes etc our Custom Design Team need to redraw all the plans to reflect your changes. This is very labour intensive and time consuming as creating a full set of working drawings with roof changes and bracing changes can take 5-7 days labour. Even a small change like a window change will still need all the plans to be altered. However our discounted Custom Design Set is dramatically cheaper than most Design Companies.

Includes: (Customised to your requirements)

- **Floor plan with all dimensions nominated**
- **Elevation Plans**
- **Electrical Plans**
- **Bracing Plans**
- **Tie Down Details**
- **Building Notes Page**
- **Sketch Plan**
- **3D Render of Façade**
- **All the above plans are classified as "Full Working Drawings"**
- **Please contact us with any questions for Custom Design Set and we will call you back to discuss it further**

Phone : 07 33 190 916

email : admin@australianfloorplans.com

BUY OUR HOME DESIGN BOOKS



[2 Storey Homes Ebook more details HERE](#)



[1 Storey Homes Ebook more details HERE](#)



[Bathrooms Ebook more details HERE](#)



[House Facades and Home Fronts details HERE](#)

BUY OUR HOME DESIGN BOOKS

DISTINCTIVE HOMES
HOUSE PLANS E-BOOK
DUPLEX/TOWNHOUSE DESIGN

AN ASSORTMENT OF INTERNATIONAL HOUSE DESIGNS
HELPING BOTH THE HOME OWNER AND BUILDERS

www.houseplansebook.com

Duplex Designs more details [HERE](#)

DISTINCTIVE HOMES
HOUSE PLANS E-BOOK
SLOPING OR-HILLSIDE DESIGNS

AN ASSORTMENT OF INTERNATIONAL HOUSE DESIGNS
HELPING BOTH THE HOME OWNER AND BUILDERS

www.houseplansebook.com

DISTINCTIVE KITCHENS
TOP 100 DESIGNS

A SPECTACULAR SELECTION OF LUXURIOUS
TOP 100 KITCHEN DESIGNS

www.houseplansebook.com

DISTINCTIVE KIDS ROOMS
TOP 100 DESIGNS

A SPECTACULAR SELECTION OF DISTINCTIVE
TOP 100 KIDS ROOMS

www.houseplansebook.com

BUY OUR HOME DESIGN BOOKS



DISTINCTIVE HOMES
HOUSE PLANS E-BOOK
GRANNY FLATS/HOME OFFICE DESIGNS

AN ASSORTMENT OF INTERNATIONAL HOUSE DESIGNS
HELPING BOTH THE HOME OWNER AND BUILDERS

www.houseplansebook.com



DISTINCTIVE DINING ROOMS
TOP 100 DESIGNS

DISTINCTIVE DINING ROOMS
TOP 100 DESIGNS

A SPECTACULAR SELECTION OF LUXURIOUS
TOP 100 DINING ROOMS

www.houseplansebook.com

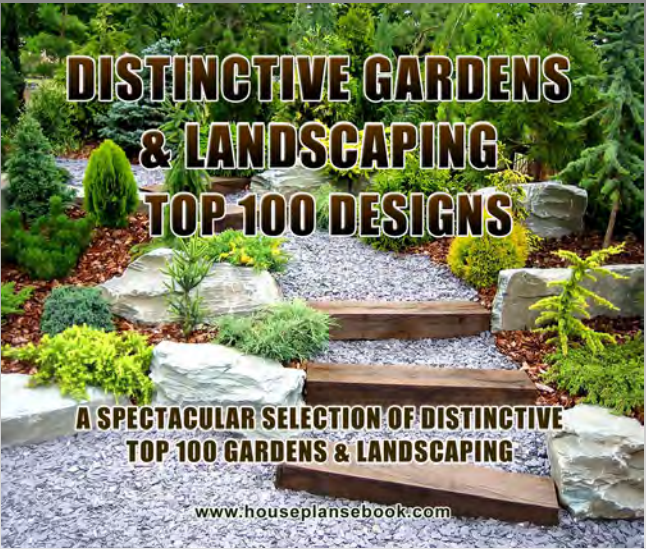

DISTINCTIVE GARDENS
& LANDSCAPING
TOP 100 DESIGNS

A SPECTACULAR SELECTION OF DISTINCTIVE
TOP 100 GARDENS & LANDSCAPING

www.houseplansebook.com



DISTINCTIVE OUTDOOR LIVING
TOP 100 DESIGNS

A SPECTACULAR SELECTION OF DISTINCTIVE
TOP 100 OUTDOOR LIVING AREAS

www.houseplansebook.com

BUY OUR HOME DESIGN BOOKS



**DISTINCTIVE LIVING ROOMS
TOP 100 DESIGNS**

**A SPECTACULAR SELECTION OF LUXURIOUS
TOP 100 LIVING ROOMS**

www.houseplansebook.com



**DISTINCTIVE BEDROOMS
TOP 100 DESIGNS**

**A SPECTACULAR SELECTION OF LUXURIOUS
TOP 100 BEDROOMS**

www.houseplansebook.com



**DISTINCTIVE SWIMMING POOLS
TOP 100 DESIGNS**

**A SPECTACULAR SELECTION OF DISTINCTIVE
TOP 100 SWIMMING POOLS**

www.houseplansebook.com

Interior Design Companion
Ideal for interior home design



- Design ideas and set out plans
- Bid forms get the best quote from suppliers
- Best selling ideas
- Colour tips

Looking for design and colour ideas

www.australianfloorplans.com

**TO REMOVE THIS NOTICE AND HAVE FULL USE OF PLANS
BUY OUR CONCEPT PLANS AND LICENCE PACK Only \$49.95**

www.australianfloorplans.com